

LEVEL GAUGE-LGS

FEATURES

- The unit is supplied with washer and O-ring type construction
- 4 sizes are available 3", 5" 7" & 10" between bolt center
- Suitable for mineral and petroleum-based oils
- The temperature scale is between 20°C to 80°C, maximum working temperature 80°C
- working for non-pressurized tanks only

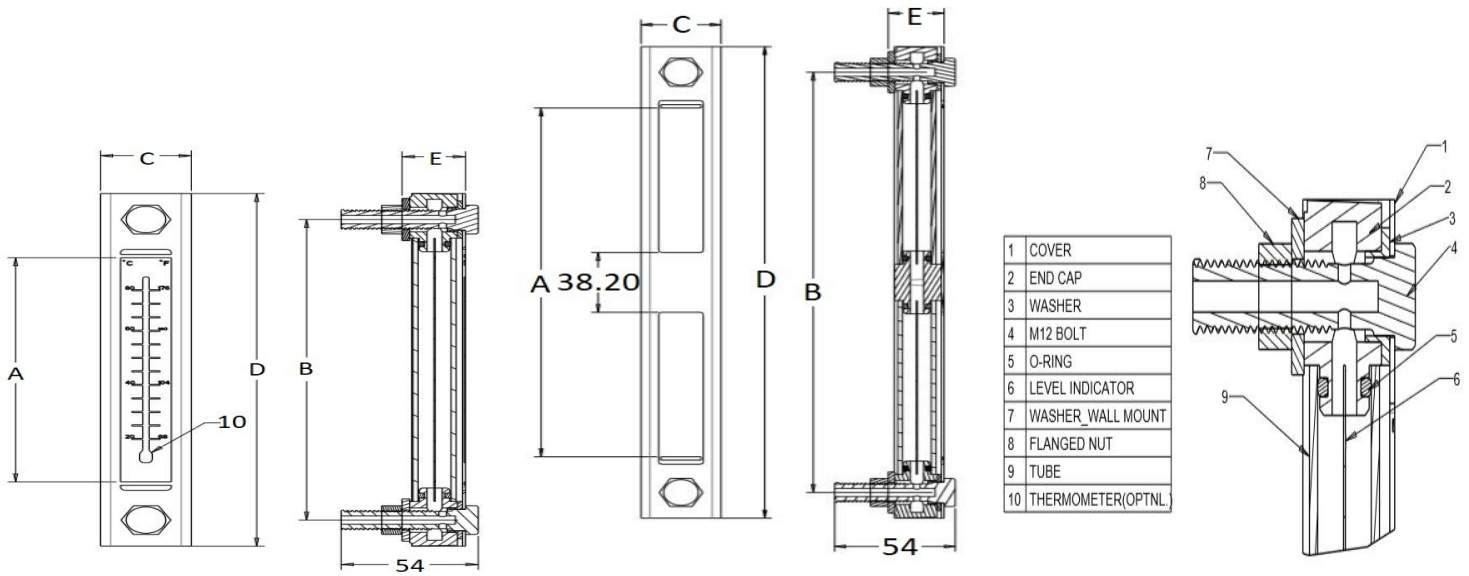

LGS-03,05&07"

LGS-10"

MODEL	A	B	C	D	E	BOLT THREAD	WEIGHT IN KG
LGS-03	27.20	76	35.80	107	25	M12	0.21
LGS-05	78	127	35.80	157.80	25	M12	0.22
LGS-07	128.8	178	35.80	208.60	25	M12	0.23
LGS-10	205	254	35.80	285	25	M12	0.34

ORDERIG CODE: ASSEMBLY

LGS	-03	_*_*
SERIES	SIZE (INCH)	FEATURE-1
LGS-STEEL BODY	03 - 3"	T-THERMOMETER (OPTIONAL)
	06 - 6"	
	07 - 7"	
	10 - 10"	

Note: All dimensions are in mm for reference