

# LEVEL GAUGE-LGA

## FEATURES

- The unit is supplied with washer and O-ring type construction
- 4 sizes are available 3", 5", 7" & 10" between bolt center
- Suitable for mineral and petroleum-based oil
- The temperature scale is between 20°C to 80°C, maximum working temperature 80°C
- working for non-pressurized tanks only

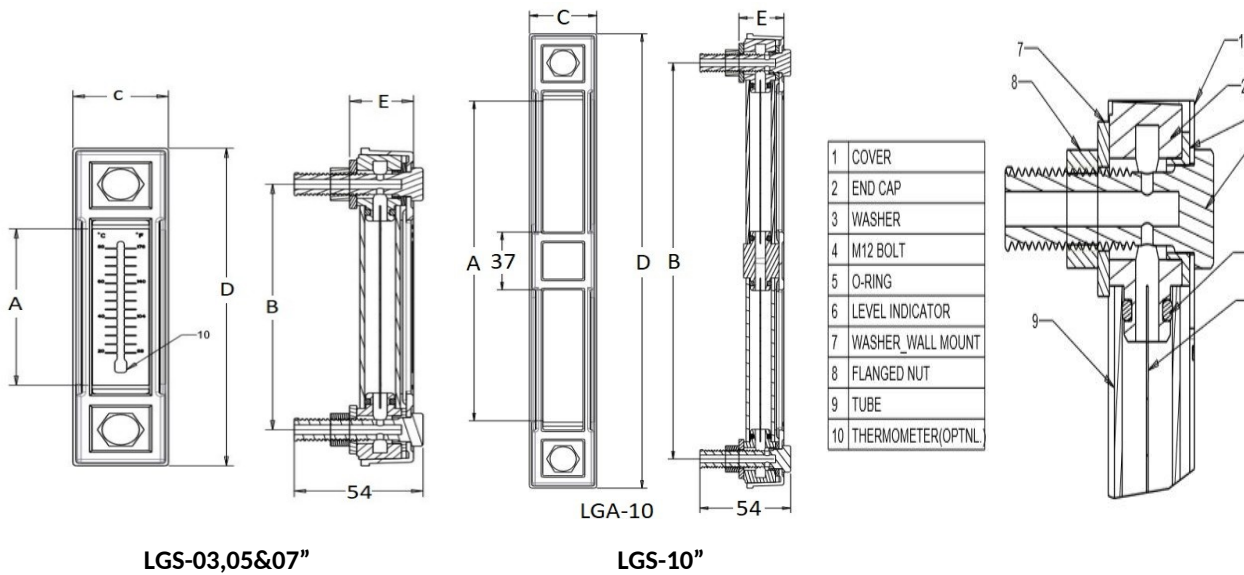

LGS-03,05&07"

LGS-10"

MODEL	A	B	C	D	E	BOLT THREAD	WEIGHT IN KG
LGA-03	27.20	76	40	113.60	26.80	M12	0.19
LGA-05	78	127	40	164.40	26.80	M12	0.20
LGA-07	128.8	178	40	215.20	26.80	M12	0.22
LGA-10	205	254	40	291.40	26.80	M12	0.27

## ORDERIG CODE: ASSEMBLY

LGA	-03	-**
SERIES	SIZE (INCH)	FEATURE-1
LGA-ALUMINIUM BODY	03 - 3"	T-THERMOMETER (OPTIONAL)
	06 - 6"	
	07 - 7"	
	10 - 10"	

Note: All dimensions are in mm for reference